

UDC 62-233.27

DOI: <https://doi.org/10.20535/0203-3771462023302705>Ortamevzi Gurkan¹, *Ph.D, Dr. Lecturer*

THE EFFECT OF GYROSCOPIC FORCE ON THE LIFE OF THE UAV'S PROPELLER SHAFT BEARING UNDER INTENSE ACROBATIC MOVEMENTS

Ua

Розглядаються сили, що діють на вал гвинта двигуна безпілотного повітряного судна. Зокрема, проаналізовано термін служби підшипників валу гвинта, що працюють під дією гіроскопічних сил. Вплив напруги від гіроскопічних сил і сили тяги на вал гвинта було проаналізовано методом кінцевих елементів шляхом моделювання валу гвинта у 3D і створення математичної моделі. Передбачається, що це безпілотне повітряне судно літає з інтенсивними акробатичними рухами або що поверхня руля висоти та керма є великою.

En

The forces acting on the propeller shaft of an unmanned aerial vehicle engine are examined. In particular, the lifespan of propeller shaft bearings operating under gyroscopic forces has been analyzed. The stress effects of gyroscopic forces and thrust force on the propeller shaft were analyzed by finite element method by modeling the propeller shaft in 3D and creating a mathematical model. It is predicted that this unmanned aerial vehicle flies with intense acrobatic movements or that the elevator and rudder surface areas are large.

¹ Alanya Alaaddin Keykubat University, Antalya, Turkiye

Introduction

While the acrobatic mobility of unmanned aerial vehicles is increasing, it also brings with it some problems. In this article, the effect of the forces occurring on the engine propeller during acrobatic movements on the life of the propeller shaft bearings is examined. In conventional aircraft, the thrust created by the propeller affects the shaft and bearing design. However, for an aircraft performing acrobatic movements, shaft and bearing designs must be made by taking into **account the gyroscopic (Coriolis) force** occurring on the propeller, as well as the thrust force. Even if the shaft design is traditional, the data in this article will shed light on establishing bearing maintenance intervals for an aircraft operating under intense gyroscopic forces [1], [2].

In the study, a force package consisting of theoretically created forces such as gyroscopic forces, Coriolis force, and other inertial forces is radially; The propeller shaft is modeled so that the thrust force acts axially on the propeller shaft. In addition, the 3D model and mathematical model of the shaft were created and the stress state of the shaft was analyzed using the finite element method. [3], [4], [5].

Theory

A two-bladed propeller was chosen in this study to theoretically calculate the forces that would affect the operation of the shaft bearings in an aircraft flying with intense acrobatic movements. Since the resultant force of the centrifugal force, which is one of the forces acting on an aircraft propeller without dynamic balance, will be 0 on the shaft, the centrifugal force is ignored for this study. In other words, centrifugal force will not affect the bearing life [6], [7], [8], [9].

Inertial and gyroscopic forces acting on a propeller

The change in the speed vectors adverts to the accelerated motions of the rotating propeller mass that generate their inertial and gyroscopic forces f_{in} and the inertial torque T_{in} acting around axis oy that is expressed by the equation (1) [1]. Inertial and gyroscopic forces acting on propeller, torques and motions of the propeller have shown in the fig. 1.

$$T_{in} = f_{in}x_m = ma_zx_m. \quad (1)$$

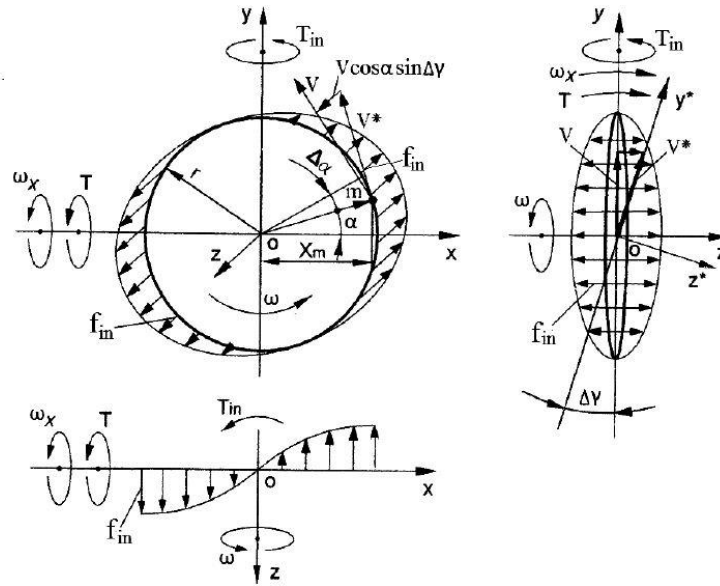

Fig. 1. Inertial and gyroscopic forces acting on propeller, torques and motions of the propeller

Coriolis forces acting on a propeller

The resistance torque generated by the Coriolis force of the blade’s mass is expressed by the equation (2). [1] Coriolis forces acting on propeller, torques and motions of the propeller have shown in the fig. 2.

$$T_{cr} = -f_{cr} y_m = -m a_z y_m . \tag{2}$$

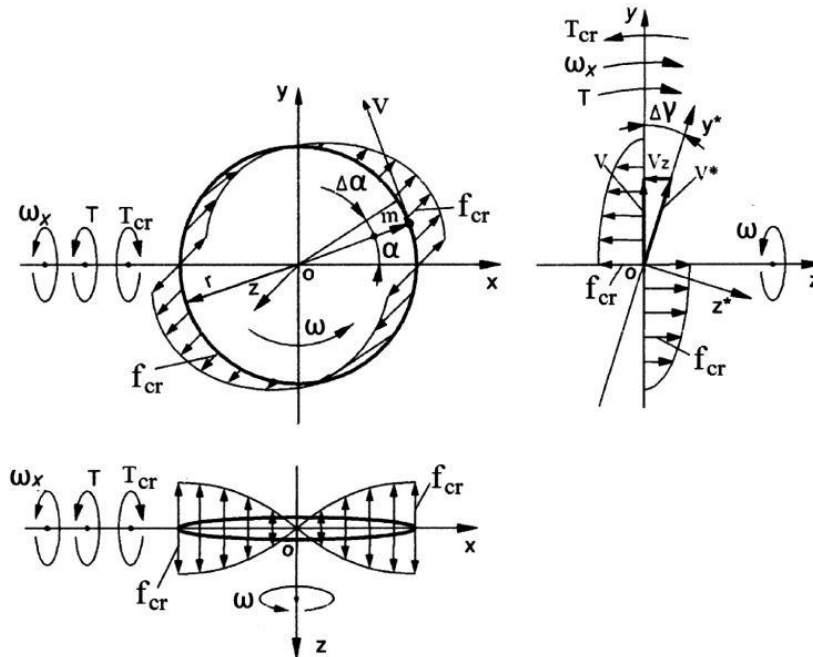

Fig. 2. Coriolis forces acting on propeller, torques and motions of the propeller

Theoretical bearing life calculation

There are some theories for predicting bearing life calculations. The most important of these theories is known as the Hertz Contact Stress theory. However, according to the Weibull Analysis, the prediction of bearing life calculations can be predicted statistically[10] according to (3), bearing life can be predicted simply.

L_{10} is million revolving number of total at 90% fatigue life estimate of the bearing that calculation as follows:

$$L_{10} = \left(\frac{C_D}{P_{eq}} \right)^3 \quad (3)$$

Empirically modified the dynamic load capacity C_D for ball bearings as follows:

$$C_D = f_c \frac{-id^2 Z^{2/3} \cos\beta}{1 + 0,02d} \quad (4)$$

where f_c – material-geometry coefficient;

i – number of rows of rolling elements (balls or rollers);

d – ball or roller diameter;

Z – number of rolling elements (balls or rollers) in a row;

β – bearing contact angle.

Equivalent Load as follows:

$$P_{eq} = XF_r + YF_a \quad (5)$$

where P_{eq} the equivalent load,

F_r the radial component of the actual load,

F_a the axial component of the actual load,

X rotation factor,

Y the thrust factor of the bearing.

3D Model and Mathematical Model

The propeller shaft mechanism of an aircraft engine, which is frequently used in unmanned aerial vehicles, is shown in fig. 3.

A 3D model and mathematical model were created to primarily determine the stress state of the propeller shaft operating under specified forces. The 3D model and mathematical model of the shaft are shown in figures 4 and 5. Statistics of mesh for the mathematical model consists of 281948 nodes and 164328 elements.

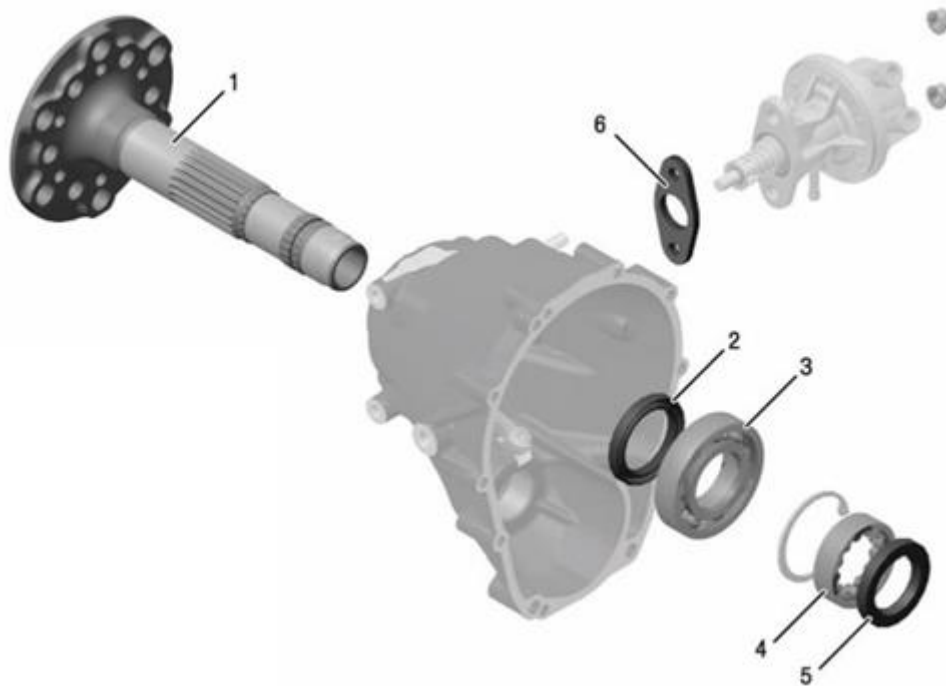

Fig. 3. A frequently used propeller shaft mechanism: 1. Propeller shaft, 2. Oil seal 40x55x7, 3. Ball bearing 35-72-17, 4. Roller bearing, 5. Oil seal 30x52x7, 6. Isolating flange

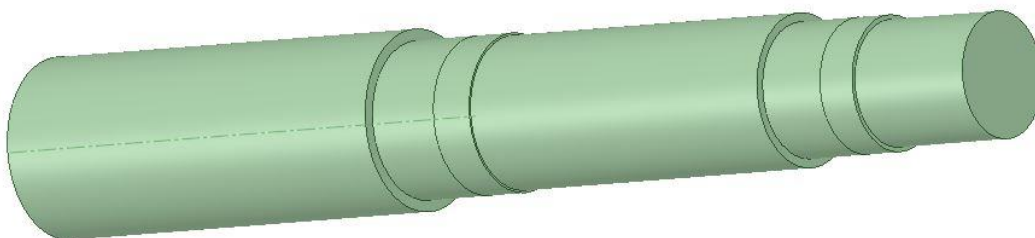

Fig. 4. 3D model of propeller shaft

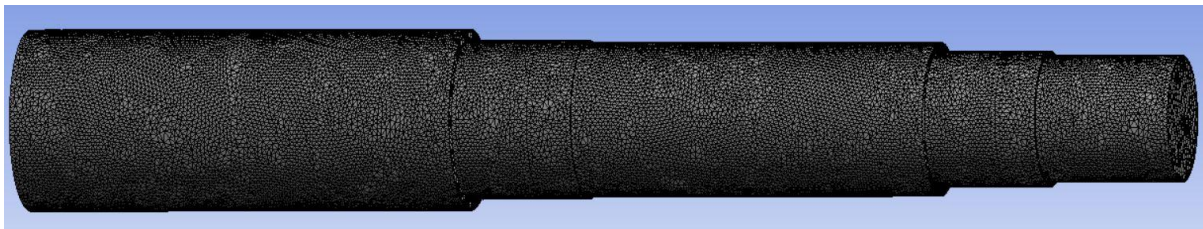

Fig. 5. Mathematical model of propeller shaft

21 different situations were simulated by increasing the thrust force as 2050 N axially and the radial forces package by 20 N between 0-200 N and combining them in both F_y and F_x directions. The gyroscopic force during yaw movement is defined as F_y , and the gyroscopic force during pitch movement is

defined as F_z . The resultant force for the largest combination of forces applied to the shaft is shown in fig. 6.

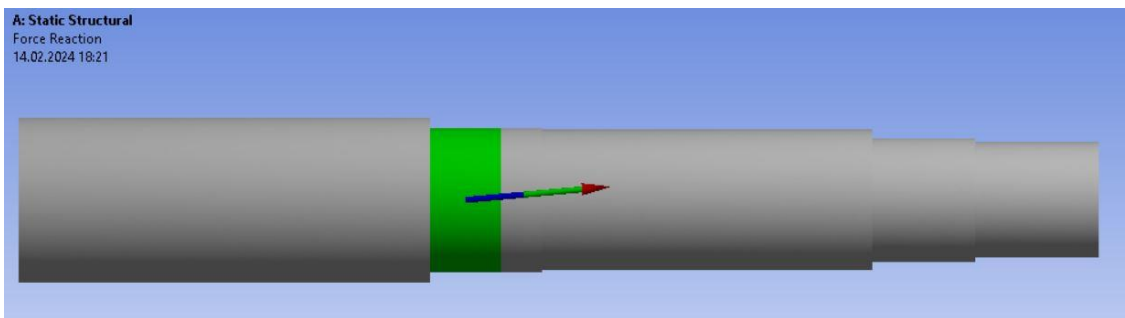

Fig. 6. Simulation of the forces applied on the shaft

Although bearing life calculation programs give adequate results for theoretical comparison. Preloading is applied to the deep groove bearings to hold under control the vibration and noise performance[11], [12], [13], [14]. By creating a model of the same shaft in the Bearinx Easy Friction bearing life calculation program offered by the bearing manufacturer FAG, the lifespan of the 6207 and 6206 bearings on which the shaft rotates was calculated. The created shaft model is shown in fig. 7.

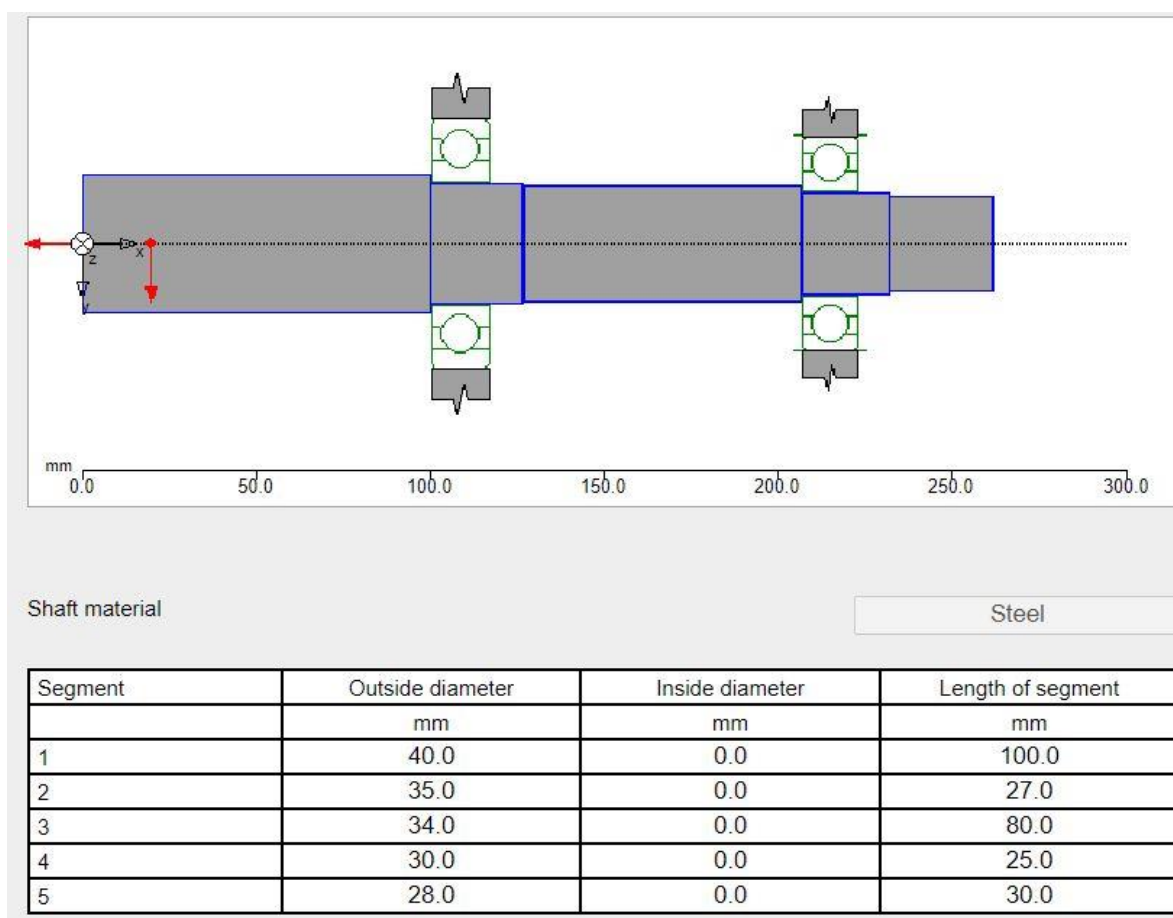

Fig. 7. Shaft model created for bearing life calculation purposes

Results and Discussion

As a result of the stress analysis of the propeller shaft using the finite element method, it was observed that the stress intensity was 11 MPa at the bearing point of the 6207 bearing. The reaction force magnitude on the bearing inner ring was also obtained from this analysis to calculate the bearing life. The stress concentration in the shaft is shown in fig. 8.

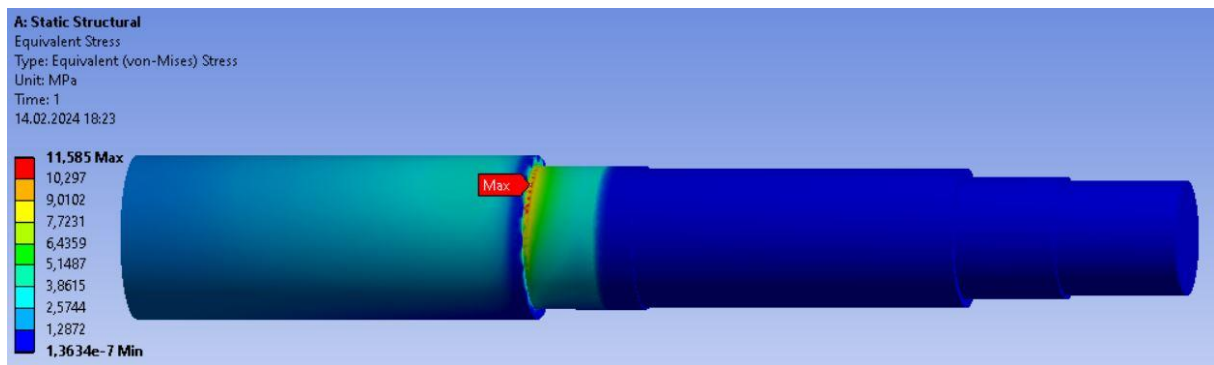

Fig. 8. Stress intensity

The results of the Bearinx Easy Friction bearing life calculation program, the predicted operating hours of 6207 and 6206 bearings according to different force packages are graphed in fig. 9 and fig. 10.

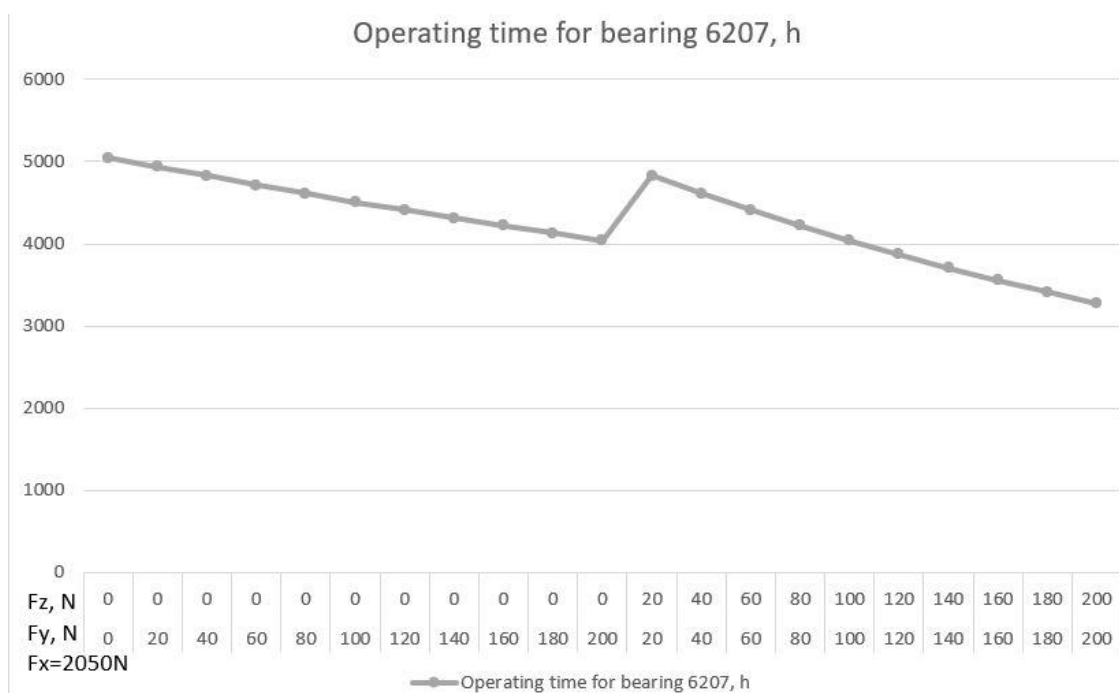

Fig. 9. Operating time for bearing 6207

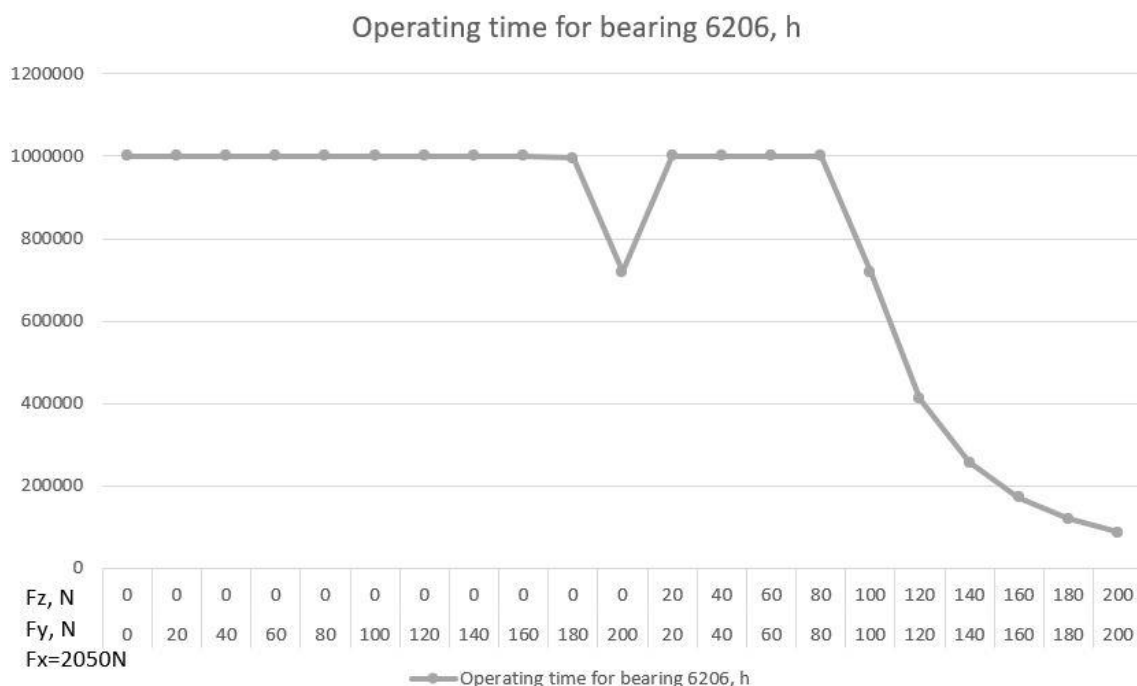

Fig. 10. Operating time for bearing 6206

Conclusion

1. Stress was observed in the bearing stage of the propeller shaft and propeller bearing of the aircraft flying during intense aerobatic movements. When designing this shaft, it is beneficial to use methods that reduce the stress concentration of this area.
2. It has been observed that the life of the bearing close to the propeller will decrease during aerobatic movements, both yaw and pitch movements. In aircraft that are heavily exposed to these movements, bearing maintenance intervals near the propeller should be reduced by approximately 20%.
3. It has been observed that the life of the propeller shaft bearing, which is exposed to the forces occurring during both yaw and pitch movements at the same time, decreases dramatically. When designing propeller shafts that will be heavily exposed to aerobatic movements, it is beneficial to have the dimensions of the propeller remote bearing as the propeller near bearing. It is difficult to replace the propeller remote bearing during maintenance.

References

1. R. Usubamatov and T. Zhumaev, "Inertial Forces Acting on a Propeller of Aircraft," *Open Aerosp. Eng. J.*, vol. 7, no. 1, 2018.
2. R. Usubamatov, "A rotating body about the fixed point is subjected by inertial torques," *Int Robot Autom. J.*, vol. 7, no. 3, pp. 75–76, 2021.

3. J. Morris, "Some Dynamical Characteristics of Propellers," *Aeronaut. J.*, vol. 38, no. 288, pp. 987–997, 1934.
4. A. Otter, J. Murphy, and C. J. Desmond, "Emulating aerodynamic forces and moments for hybrid testing of floating wind turbine models," in *Journal of Physics: Conference Series*, 2020, vol. 1618, no. 3, p. 32022.
5. P. C. Teixeira and C. E. S. Cesnik, "Propeller influence on the aeroelastic stability of High Altitude Long Endurance aircraft," *Aeronaut. J.*, vol. 124, no. 1275, pp. 703–730, 2020.
6. M. N. Armenise, C. Ciminelli, F. Dell'Olio, and V. M. N. Passaro, *Advances in gyroscope technologies*. Springer Science & Business Media, 2010.
7. Y. Wang, J. Yang, X. Li, G. Sun, and T. Lim, "Interaction of gear-shaft dynamics considering gyroscopic effect of compliant driveline system," *SAE Int. J. Passeng. Cars-Mechanical Syst.*, vol. 8, no. 2015-01-2182, pp. 742–747, 2015.
8. W. H. Reed III and S. R. Bland, "An analytical treatment of aircraft propeller precession instability," 1961.
9. H. Hamdi, C. Mrad, A. Hamdi, and R. Nasri, "Dynamic response of a horizontal axis wind turbine blade under aerodynamic, gravity and gyroscopic effects," *Appl. Acoust.*, vol. 86, pp. 154–164, 2014.
10. E. V Zaretsky, "Rolling bearing life prediction, theory, and application," *NASA Tech. Reports*, no. November 2016, p. 66, 2013, [Online]. Available: <http://www.sti.nasa.gov>.
11. T. A. Harris, *Rolling bearing analysis*. John Wiley and sons, 2001.
12. T. IGARASHI, "Noise of ball bearing in electric motor," *Bull. JSME*, vol. 7, no. 25, pp. 200–208, 1964.
13. M. Jafarboland and H. B. Farahabadi, "Optimum design of the stator parameters for noise and vibration reduction in BLDC motor," *IET Electr. Power Appl.*, vol. 12, no. 9, pp. 1297–1305, 2018.
14. Y. Fang and T. Zhang, "Vibroacoustic characterization of a permanent magnet synchronous motor powertrain for electric vehicles," *IEEE Trans. Energy Convers.*, vol. 33, no. 1, pp. 272–280, 2017.